



IGS Technical Note

Contact IGS

www.insitu.com.au
0407 INSITU (0407 467 488)
Fax 07 3358 4366

Contact Allan McConnell

allan@insitu.com.au
0417 748 669

Geotechnical Services

CPT & Piezocone
Dilatometer
Seismic Dilatometer
Vane Shear
Tee-Bar
Push-Sampling
Piezometer Installation
In Situ Permeability

Field Fleet ("the girls")

Esme – 10-20t all-terrain



Beryl – 15t 4 wheel drive



Eunice – 20t 6x4 bogey



Baby Jayne – 15t portable



Our PPI Sampler

(for better quality samples in soft ground)

- IGS Design - unique
- 316 stainless tube
- stationary piston
- 63mm OD x 1.6mm wall
- area ratio ~ 10%
- nil pull-out suction
- samples anything soft

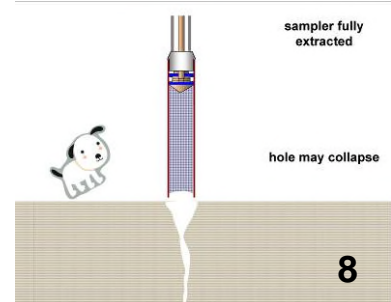
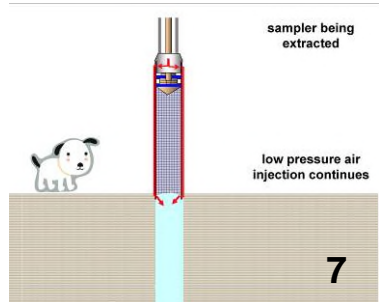
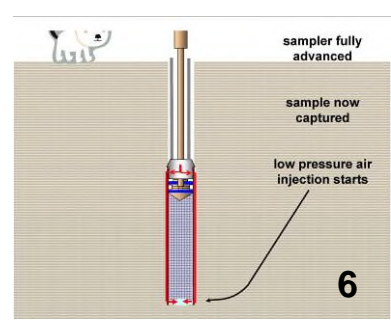
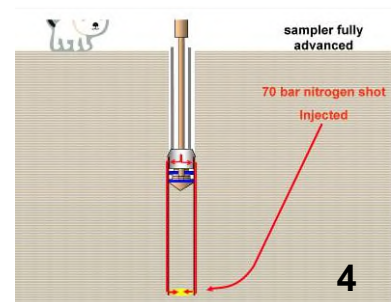
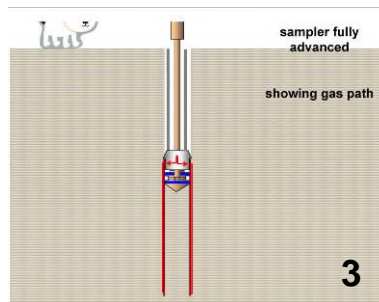
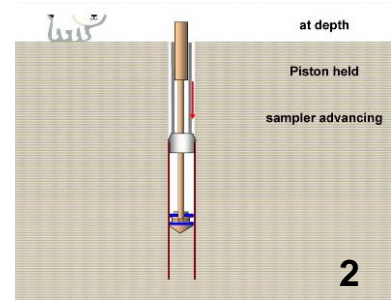
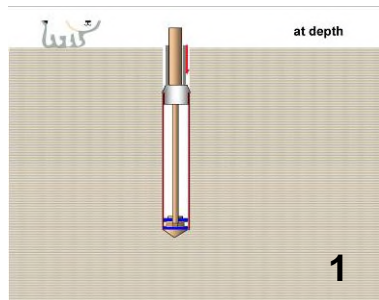

reducing geotechnical uncertainty